

Ma

KEY STAGE

3

HIGHER TIERS
TEST A

2005

Mental mathematics Test A Audiotape/CD transcript

This booklet contains a transcript of the key stage 3 mental mathematics Test A. It should be used **ONLY** in cases of recording malfunction or for specific special arrangements made for the administration of this version of the test for pupils with sensory and/or motor disabilities. The practice question for the mental mathematics test is included within the subject-specific guidance.

2005



department for

education and skills

creating opportunity, releasing potential, achieving excellence

Sourced from SATs-Papers.co.uk

<https://www.SATs-Papers.co.uk>

'Now we are ready to start the test.'

For the first group of questions you will have 5 seconds to work out each answer and write it down.'

1	How many sixes are there in fifty-four?
2	Look at your answer sheet. Write the coordinates of the point marked A.
3	The population of France is approximately sixty-one million. Write this number in figures.
4	How many millimetres are there in one metre?
5	Write a different fraction that is equivalent to three-fifths.
6	What is six point two multiplied by one thousand?
7	Look at the diagram. The lines marked with arrows are parallel. What is the size of angle p ?
8	Round three point seven nine five to one decimal place.

'For the next group of questions you will have 10 seconds to work out each answer and write it down.'

9	The scale on a map is one centimetre to five metres. On the map the length of a street is eight centimetres. What is the real length of the street in metres?
10	Write down a number that is a multiple of three and is also a multiple of five.
11	Two of the angles in a triangle are sixty degrees and seventy degrees. What is the size of the third angle?
12	I start at seven and count down in equal steps; seven, four, one. Write down the next two numbers.
13	Look at the expression on your answer sheet. Write it as simply as possible.
14	What is eighteen multiplied by nine?
15	The perimeter of a rectangle is twenty centimetres. Its length is seven centimetres. What is the width of the rectangle?
16	Five per cent of a number is sixteen. What is twenty-five per cent of the number?
17	Look at the equation on your answer sheet. What is the value of a ?

'Now turn over your answer sheet.'

Key stage 3 mathematics 2005
Mental mathematics Test A

First name _____
Last name _____
School _____

Total marks

Time: 5 seconds continued

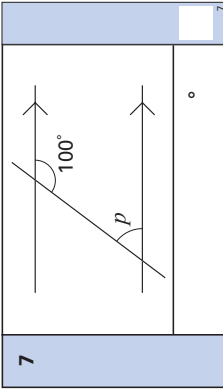
6	<input type="text"/>	6.2	<input type="text"/>
7			<input type="text"/>
8	<input type="text"/>	3.795	<input type="text"/>

Practice question

<input type="text"/>	38	12
----------------------	----	----

Time: 10 seconds

9	<input type="text"/>	m	1cm : 5m	<input type="text"/>
10	<input type="text"/>	3	5	<input type="text"/>
11	<input type="text"/>	°	60° 70°	<input type="text"/>
12	7	4,	1,	<input type="text"/>
13	<input type="text"/>	$6g + 4h + 3g - 2h$		<input type="text"/>
14	<input type="text"/>	18	9	<input type="text"/>
15	<input type="text"/>	cm	20cm 7cm	<input type="text"/>
16	<input type="text"/>	5%	16	<input type="text"/>
17	<input type="text"/>	$32 - 2a = 24$		<input type="text"/>

Time: 5 seconds

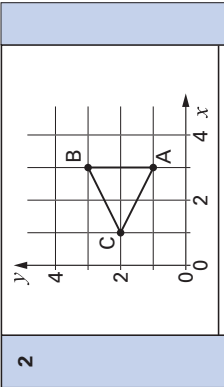
1	<input type="text"/>	54	<input type="text"/>
2			<input type="text"/>
3	<input type="text"/>	<input type="text"/>	<input type="text"/>
4	mm	1m	<input type="text"/>
5	<input type="text"/>	$\frac{3}{5}$	<input type="text"/>

18	Estimate the value of nine point two multiplied by two point nine.
19	I drive ten kilometres in twelve minutes. What is my average speed in kilometres per hour?
20	Look at the expression on your answer sheet. Multiply out the brackets.

'For the next group of questions you will have 15 seconds to work out each answer and write it down.'

21	The pictogram shows the number of girls and boys in a youth club. How many more girls than boys are in the youth club?
22	The pie chart shows the colour of cars in a car park. There were twelve blue cars. Approximately, how many cars were there altogether?
23	When a equals minus three and b equals minus seven, what is the value of a minus b ?
24	The mean of three numbers is six. Two of the numbers are five. What is the third number?
25	A circle has a radius of six centimetres. Give an approximate value for the circumference of the circle.
26	What is two-thirds of three-quarters of eighty?
27	Look at the frequency table showing the number of people travelling in cars. Altogether, how many people were travelling?
28	A rectangle has an area of eight square centimetres. What is the area of a rectangle with sides that are all twice as long?
29	Look at the graphs. Put a ring round the graph that has the equation y equals x plus one.
30	Look at the numbers on your answer sheet. Write down the number that is halfway between them.

'Put your pens down. The test is finished.'

Time: 10 seconds continued

18	9.2	2.9	18
19	10 km	12 minutes	19
		km/h	
20	$2a(a + 4)$		20

Time: 15 seconds

21	<table border="1"> <tr> <td>Girls</td> <td>● ● ● ● ●</td> </tr> <tr> <td>Boys</td> <td>● ● ● ● ●</td> </tr> </table> <table border="1"> <tr> <td>●</td> <td>= 4 people</td> </tr> </table>	Girls	● ● ● ● ●	Boys	● ● ● ● ●	●	= 4 people	21
Girls	● ● ● ● ●							
Boys	● ● ● ● ●							
●	= 4 people							

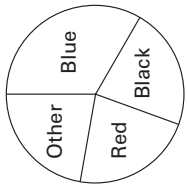
22		22
----	--	----

23	$a = -3$ $b = -7$	23
	$a - b$	

24	5 5	24
	

Time: 15 seconds continued

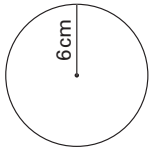
25		25
	cm	

26	$\frac{2}{3}$ $\frac{3}{4}$ 80	26

27	<table border="1"> <tr> <td>No. of people</td> <td>1</td> <td>2</td> <td>3</td> <td>4</td> </tr> <tr> <td>Frequency</td> <td>5</td> <td>4</td> <td>0</td> <td>1</td> </tr> </table>	No. of people	1	2	3	4	Frequency	5	4	0	1	27
No. of people	1	2	3	4								
Frequency	5	4	0	1								
	people											

28	cm ²	8 cm ²	28
----	-----------------	-------------------	----

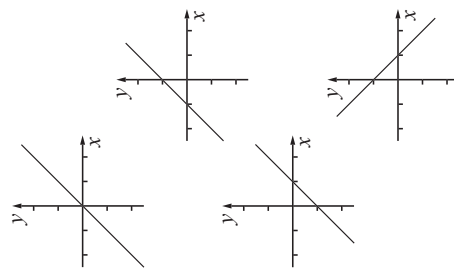
29		29
----	--	----

30	$\frac{2}{5}$ 1	30
----	-----------------	----

First published in 2005

© Qualifications and Curriculum Authority 2005

Reproduction, storage, adaptation or translation, in any form or by any means, of this publication is prohibited without prior written permission of the publisher, unless within the terms of licences issued by the Copyright Licensing Agency. Excerpts may be reproduced for the purpose of research, private study, criticism or review, or by educational institutions solely for educational purposes, without permission, provided full acknowledgement is given.

Produced in Great Britain by the Qualifications and Curriculum Authority under the authority and superintendence of the Controller of Her Majesty's Stationery Office and Queen's Printer of Acts of Parliament.

The Qualifications and Curriculum Authority is an exempt charity under Schedule 2 of the Charities Act 1993.

Qualifications and Curriculum Authority
83 Piccadilly
London
W1J 8QA
www.qca.org.uk/

Further teacher packs may be purchased (for any purpose other than statutory assessment) by contacting:

QCA Orderline, PO Box 29, Norwich NR3 1GN
tel: 08700 606015; fax: 08700 606017